

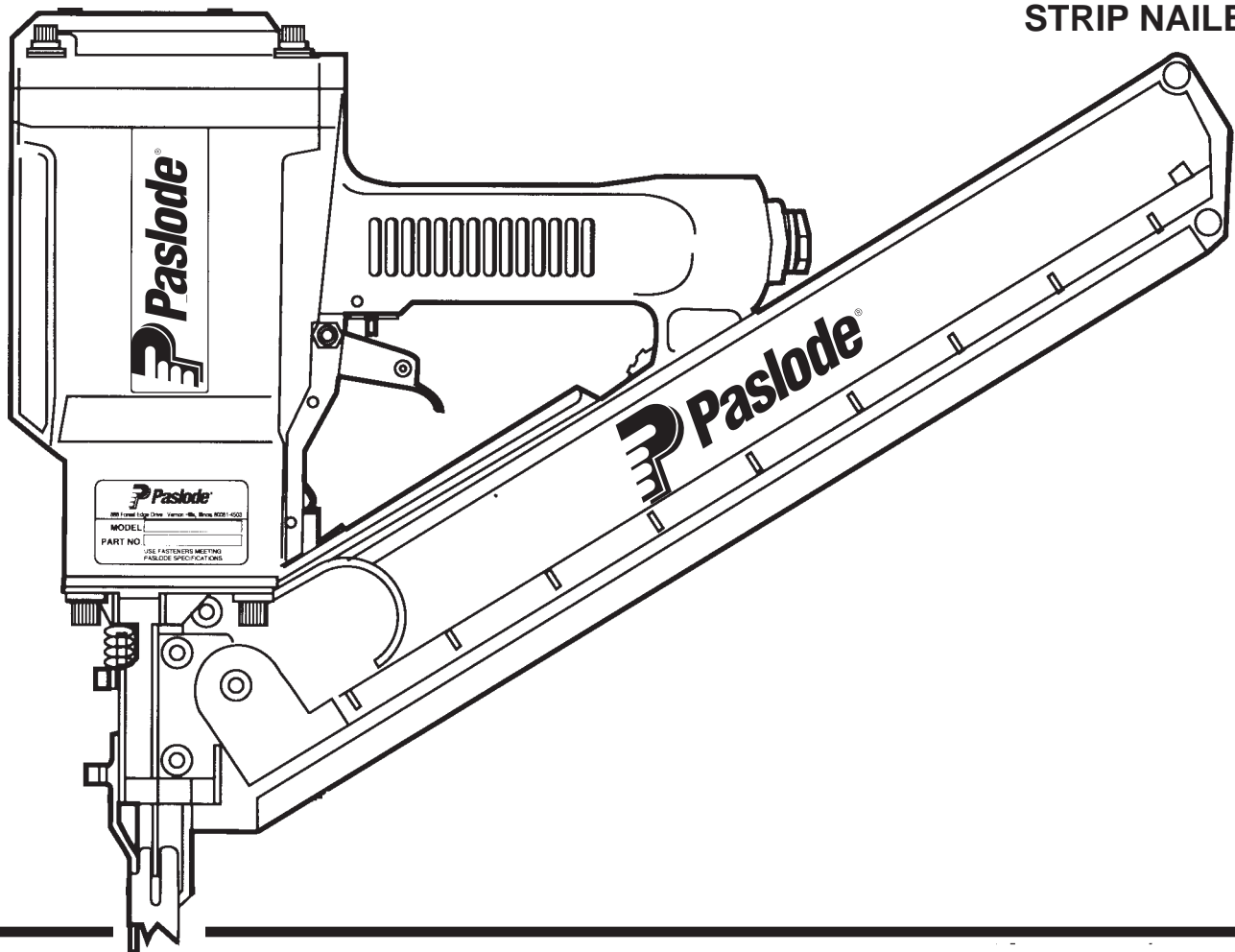

MODEL 5325/80S
MODEL 5350/90S
MODEL 5300/75S Plus
STRIP NAILERS



**IMPORTANT!
DO NOT DESTROY**

Always refer to safety and maintenance manual #403606 for detailed information this tool. It is the customers responsibility to have all operators and service personnel read and understand this information.

TOOL SCHEMATIC AND PARTS

PARTS LEGEND

5325/80S, 404030
5350/90S, 402025
5300/75S PLUS, 403040

▲ 1	013625	9	Socket Head Capscrew, #8-32 x 1/2"	57	401996	1	Spring, Knob
2	401955	6	Flat Washer, #8	58	401993	1	Knob
**3	402057	1	Air Deflector	59	401998	1	Mounting Insert
4	500453	1	Bumper, Post	*60	402008	1	Gasket, Nose Flange
5	500627	2	Screw	61	402005	1	Flange, Nose
7	092735	4	Socket Head Capscrew, 1/4-20 x 1-1/4"	62	006787	2	Roll Pin, 3/16" Dia. x 1" Lg.
7A	013567	4	Socket Head Capscrew, 1/4-20 x 2-1/2"	62A	401697	2	Roll Pin
8	002187	4	Lock Washer, 1/4"	63	401988	1	Spring, Work Contacting Element
9	092757	4	Flat Washer	64	402014	1	Lower W.CE. Bracket
10	500452	1	Cap (5325, 5300 PLUS)	65	402094	2	Flat Washer, #10
10A	500462	1	Cap (5350)	66	004238	1	Lock Washer, #10
*11	401983	1	Gasket	▲ 67	009037	2	Socket Head Capscrew, 10/32 x 1/2"
12	500407	1	Spring	68	402009	1	Work Contacting Element (5325, 5300 PLUS)
13	406041	1	Retaining Ring		401990	1	Work Contacting Element (5350)
*14	500461	1	"O" Ring, Upper Valve Piston	69	402095	1	Nut Bar
15	500455	1	Upper Valve Piston	70	401906	1	Nose (5325, 5300 PLUS)
16	401946	1	Seal, Main Valve		401907	1	Nose (5350)
*17	092042	1	"O" Ring, Lower Valve Piston	71	009016	4	Socket Head Capscrew, 5/16-18 x 1"
*18	091208	1	"O" Ring, Lower Valve Piston	72	095417	4	Lock Washer, 5/16"
*19	401950	1	"O" Ring, Lower Valve Piston	73	002442	4	Lock Washer, #8
20	500456	1	Lower Valve Piston	74	401979	1	Cover, Magazine
21	500454	1	Post	75	401978	1	Spring, Upper Work Contacting Element
22	095432	1	"O" Ring, Post	76	401977	1	Upper Work Contacting Element
▲ 23	402906	1	Button Head Capscrew, #10-32 x 5/8"	77	402010	2	Bushing
25	091861	1	Nut	78	091363	3	Flexloc Thin Nut, #8-32
26	092116	1	Washer	79	403581	1	Magazine, Right and Left, (5325) Includes Part No. 401980
*27	092971	1	"O" Ring, Piston		403732	1	Magazine, Right and Left, (5350, 5300 PLUS) Includes Part No. 401980
28	401956	1	Piston	81	401919	1	Shear Block (Including Pin), Right (5325, 5300 PLUS)
*29	401904	1	Driver Blade (5325, 5300 PLUS)		401921	1	Shear Block (Including Pin), Right (5350)
	401905	1	Driver Blade (5350)	82	401975	2	Pin, Shear Block
30	402011	1	Seal, Sleeve	83	401966	1	Follower Assembly
31	401900	1	Sleeve (5325, 5300 PLUS)	85	401918	1	Shear Block (Including Pin), Left (5325)
	401901	1	Sleeve (5350)	404660	1	Shear Block (Including Pin), Left (5300 PLUS)	
*32	092762	1	"O" Ring, Sleeve		401920	1	Shear Block (Including Pin), Left (5350)
*33	091024	1	"O" Ring, Sleeve	86	401965	1	Drum, Negator
34	401984	1	Flange	*87	401964	1	Spring, Negator
34A	402993	1	Shim	88	403042	1	Cover, Spring
*35	401985	1	"O" Ring, Flange	89	008731	1	Socket Head Capscrew, #10-24 x 3/4"
*36	401986	1	Bumper	90	404045	1	Socket Head Capscrew, #8-32 x 1-1/8"
37	401936	1	Housing	91	403738	1	Pin, Magazine
38	404937	2	Logo, Housing	92	403739	1	Spring, Magazine Pin
39	097748	1	Spring, Valve Pin	93	023766	1	Retainer Ring
40	097746	1	Valve Pin	94	090971	1	Socket Head Capscrew, #8-32 x 7/8"
*41	092174	1	"O" Ring, Valve Body	95	401961	1	Channel
42	401958	1	Valve Body	97	403740	1	Spacer, Magazine
43	026133	3	Roll Pin, 1/8" Dia. x 1" Lg.	98	091591	1	"O" Ring, End Plug
44	401992	1	Spring, Intermediate Work Contacting Element	99	401974	4	Screw with Plastite
45	401991	1	Intermediate Work Contacting Element	100	404046	1	Wear Plate Kit
46	096893	1	Name Plate	101	016343	1	Socket Head Capscrew, #8-32 x 1-1/4"
47	402079	1	Trigger Pin	**102	500458	1	Warning Label
48	404325	1	Stop Nut	103	401980	1	Bolt Knob
50	005849	1	Roll Pin	104	500488	1	Grip Handle
51	405144	1	Trigger	105	406026	4	Cup Washer, Diffuser
52	405147	1	Lever				
▲ 54	401940	1	End Plug				
55	091622	1	Reducing Pipe Bushing				
56	401997	1	Cup, Knob				

* Denotes normal wear items

**NOTE: Make sure warning label (500458) is properly affixed. Replace if necessary. Label available at no charge through the Service Dept.

▲ Apply loctite 242 (Blue) Part No. 093500

→ Denotes new change

WARNING

All parts must be periodically inspected and replaced if worn or broken. Failure to do this can affect the tool's operation and present a safety hazard.

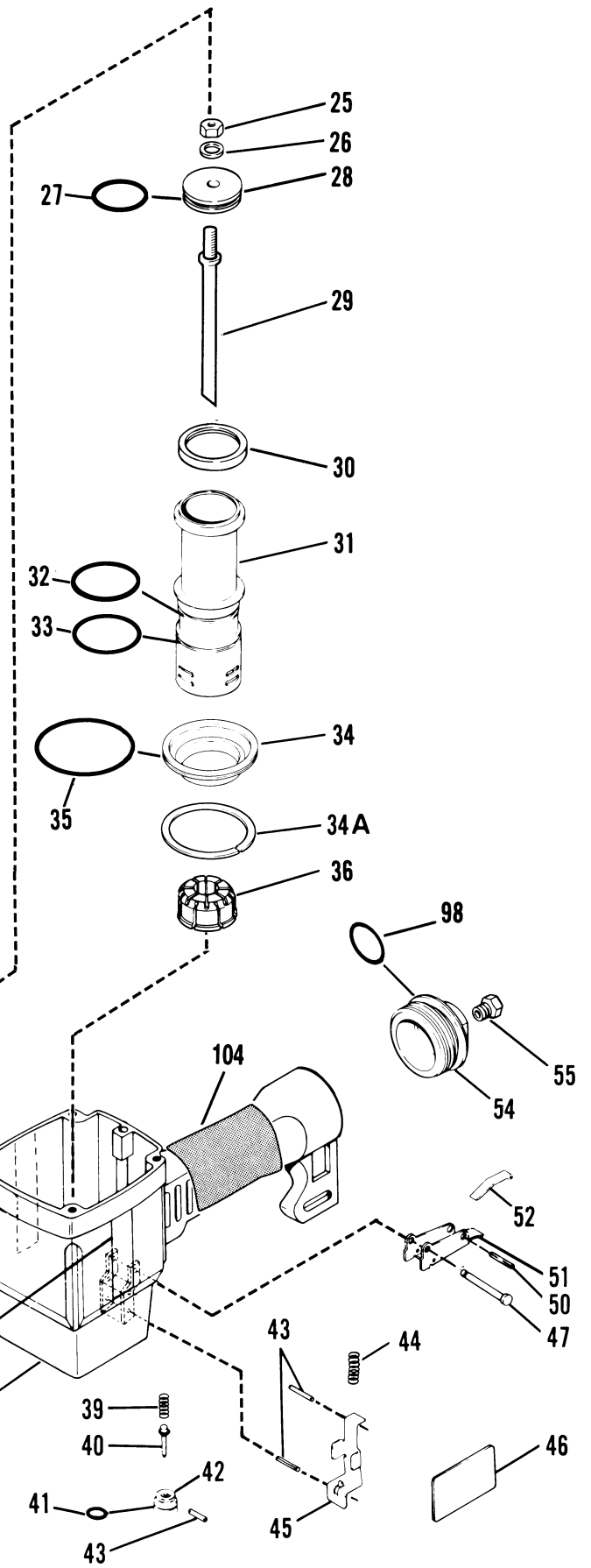
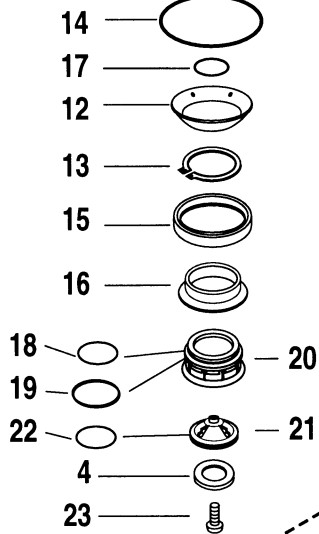
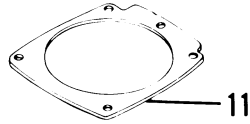
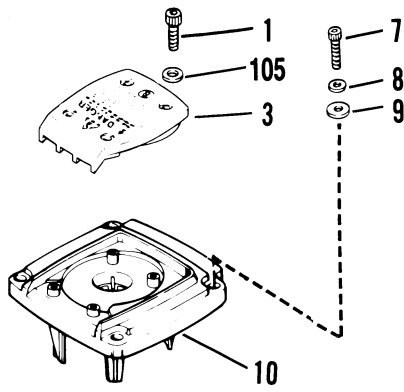
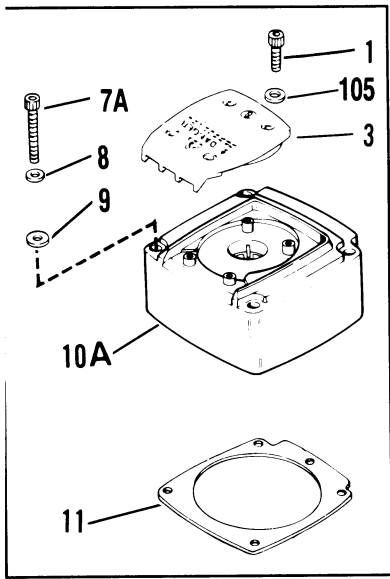

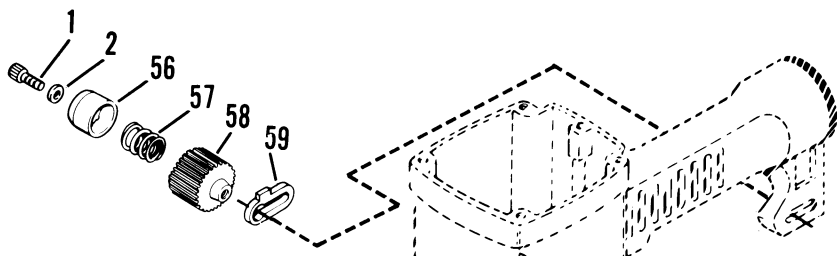

5325/80S

404030

5350/90S

402025

5300/75 PLUS

403040

5325/80SQ

404263

5350/100SQ

402050

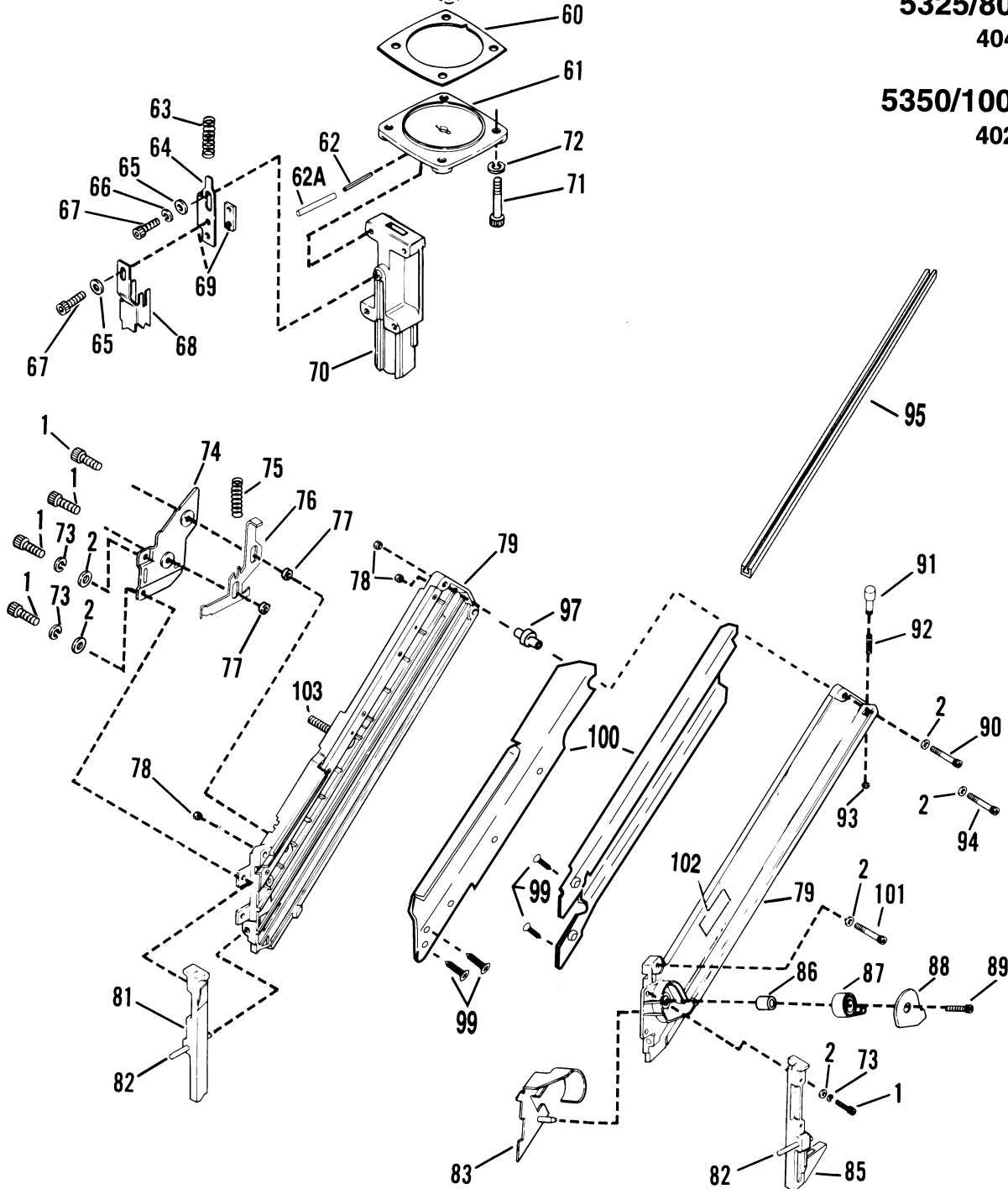

PARTS OFFERED AS ASSEMBLIES

500466 Cap Assembly (5325, 5300 PLUS) 500467 Cap Assembly (5350)

Includes

4	500453	1	Bumper, Post
10	500452	1	Cap (5325, 5300 PLUS)
10A	500462	1	Cap (5350)
12	500407	1	Spring
13	406041	1	Retaining Ring
14	500461	1	"O" Ring
15	500455	1	Upper Valve Piston
16	401946	1	Seal, Main Valve
17	092042	1	"O" Ring
18	091208	1	"O" Ring
19	401950	1	"O" Ring
20	500456	1	Lower Valve Piston
21	500454	1	Post
22	095432	1	"O" Ring
23	402906	1	Button Head Capscrew, #10-32, x 5/8"

500463 Valve Assembly (All Models)

Includes

13	406041	1	Retaining Ring
15	500455	1	Upper Valve Piston
16	401946	1	Seal, Main Valve
18	091208	1	"O" Ring
19	401950	1	"O" Ring
20	500456	1	Lower Valve Piston

401933 Piston Assembly (5325, 5300PLUS) 401934 Piston Assembly (5350)

Includes

25	091861	1	Nut
26	092116	1	Washer
27	092971	1	"O" Ring
28	401956	1	Piston
29	401904	1	Driver Blade (5325, 5300 PLUS)
	401905	1	Driver Blade (5350)

402408 Trigger Assembly (All Models)

Includes

50	005849	1	Roll Pin
51	405144	1	Trigger
52	405147	1	Lever

403847 Magazine Assembly, (5325)

403848 Magazine Assembly, (5350,5300PLUS)

Includes

2	401955	1	Flat Washer, #8
5	500627	2	Screw
74	401979	1	Magazine Cover
75	401978	1	Spring, Upper Work Contacting Element
76	401977	1	Upper Work Contacting Element
77	402010	2	Bushing
78	091363	3	Flexloc Thin Nut
79	403581	1	Magazine, Left and Right, (5325) Includes Part No. 401980
	403732	1	Magazine, Left and Right, (5350, 5300 PLUS) Includes Part No. 401980
83	401966	1	Follower Assembly
86	401965	1	Drum, Negator
87	401964	1	Spring, Negator
88	403042	1	Spring Cover
89	008731	1	Socket Head Capscrew, #10 - 24 x 3/4"
90	404045	1	Socket Head Capscrew, #8 - 32 x 1 1/8"
91	403738	1	Pin, Magazine
92	403739	1	Spring, Magazine Pin
93	023766	1	Retainer Ring
94	090971	1	Socket Head Capscrew, #8 - 32 x 7/8"
95	401961	1	Channel
97	403740	1	Spacer, Magazine
99	401974	4	Screw
100	404046	1	Wear Plate Kit
101	016343	1	Socket Head Capscrew, #8 - 32 x 1 1/4"
**102	500458	1	Warning Label

SAFETY INSTRUCTIONS

WEAR EYE AND HEARING PROTECTION



Always wear hearing protection and eye protection devices, including side shields when operating or working in the vicinity of a tool.



DO NOT EXCEED MAXIMUM RECOMMENDED AIR PRESSURE

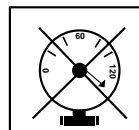

Operate the tool using only the recommended air pressure. Do not exceed the maximum air pressure marked on the tool. Be sure the air pressure gauge is operating properly and check it at least twice a day.

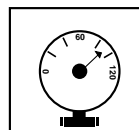

Never use any bottled air or gases such as oxygen to operate the tool since they could cause the tool to explode.

AIR CONSUMPTION CHART

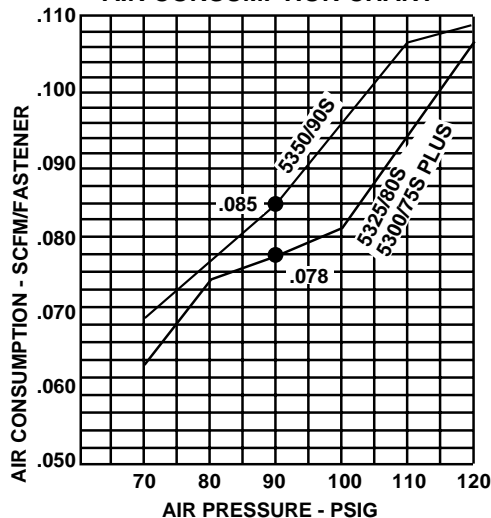

ACCESSORIES

Silencer Kit

This kit is used to minimize the sound of the air rushing out of the air deflector during tool operation.

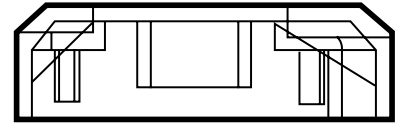

Part No. 402451

Sequential Operating Kit

This special attachment is designed for sequential operation (stops "contact" firing). The operator must depress and hold the work contacting element against the work surface before pulling the trigger. This sequence must be repeated each time the tool drives a fastener.

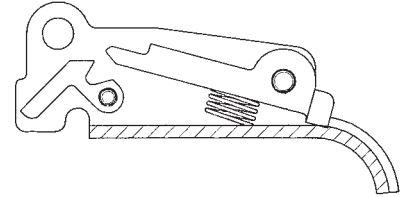

Part No. 406006

Remote Fire Valve

This valve via a positive air signal allows the machine mounted tool to be operated from an automatic air valve or foot pedal system.

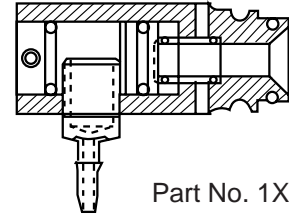

Part No. 1X0713

No Mar Work Contacting Element

For decking and siding applications where the normal work contacting element will mar the surface.

(Replacement rubber tip, Part No. 403369)

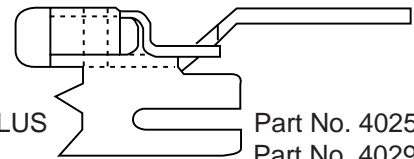

5325S, 5300S PLUS
5350S

Part No. 402508
Part No. 402995

Rafter Hanger Bracket

Allows tool to be hung over rafter during framing construction.

Part No. 219176

Hanger Bracket

Attaches to top of tool for storage or counter-balancing.

Part No. 1X0856

Lubricants

Lubricating Oil 8 oz.

Part No. 219026

Lubricating Oil with Antifreeze

Part No. 219090

Chemplex 710 Lubricant 1 lb.

Part No. 403734

Chemplex 710 Lubricant 5 gram tube

Part No. 219188

Degreaser Cleaner

Ideal Cleaner for all Paslode Tools

Part No. 219086

Safety Glasses

Clear

Part No. 402510

Tinted

Part No. 402512

Belt Hook

Part No. 219017



An Illinois Tool Works Company
888 Forest Edge Drive
Vernon Hills, Illinois 60061-4503